



특징 (Character)

- 테이퍼 슬라이딩 방식에 의한 견고한 면압구동방식
Surface pressure driving type by taper sliding
- AIR PORT의 분기구조로 선택사용이 가능하며 밀면
AIR PORT(BP)사용시 SSU 등에 적절한 조합이 가능
Possible to use by Air port's branch structure and when using
underside Airport(BP) possible to combine at SSU, etc
- 개폐 검출용 근접스위치 부착 가능합니다.
Proximity sensor is available for open-close sensing
- 원형 몸체 구조로 대상물의 중심기준 작업에 효과적
Easy to grip the center of workpiece by the cylindrical structure



AF101
AF02
AF03
AF04P
AF105P
AF06
AF10
AF13
AF13C
AF14
AF15
AF316
AF316L
AF17
AF117
AF19
AF24
AF26
AF28D
AF30(SN)
AF30L
AF30SP
AF46(SN)
AF46N
AF56N
AF56L
RAF56N
MF16

웨지 방식 (Wedge type)

작동 방식 (Kinetics)

큰힘의 중심 파지를 위한 웨지방식
wedge system for high level of power
transmission and centric gripping

센서 브래킷 [Sensor bracket]

근접 센서 부착용
brackets for proximity
switch and adjustable
control cams integrated
into the housing

구동부 (Drive)

복동식
double acting
pneumatic cylinder

조 (Jaws)

파지부
for gripping

몸체 (Body)

경질 처리된 경량의
알루미늄 합금
high-tensile aluminum body with
lightest possible because of
hard anodizing

슬라이드웨이 (Slideway)

중량물 파지시 유격을
최소화하기 위한 정밀 가공
extremely precise for gripping
with small clearance under
heavy loads

중심 취부 (Centering and mounting options)

다용도의 손쉬운 취부 방식
gripping has universal mount

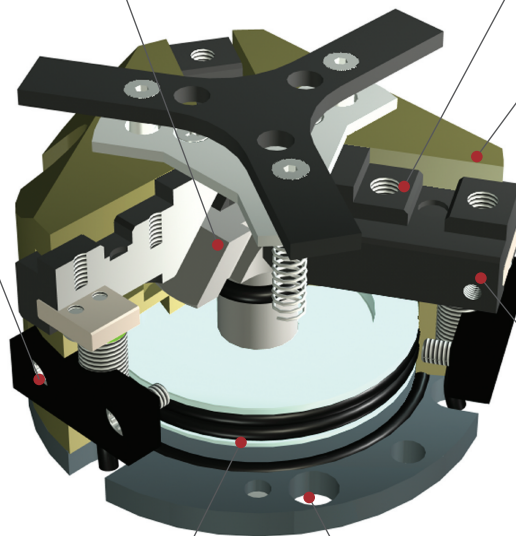

부품분해도 (Exploded view)

※ 본 분해도는 한 제품을 예시하였으므로 기종별로 차이가 있을 수 있습니다.
 ※ This is exploded view illustrates a certain product only. The contents may vary by product models.

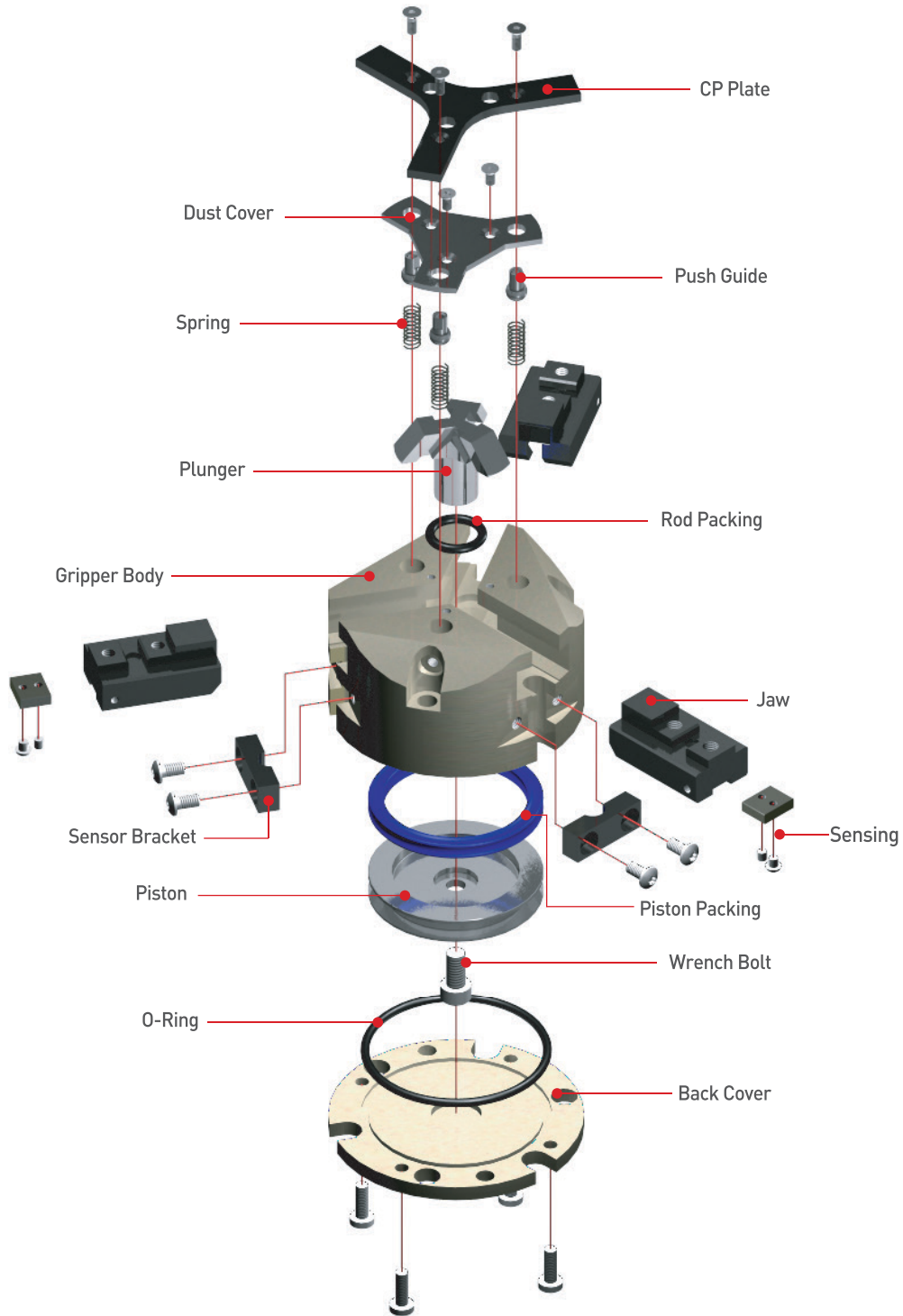

주문기호 (Ordering Code)

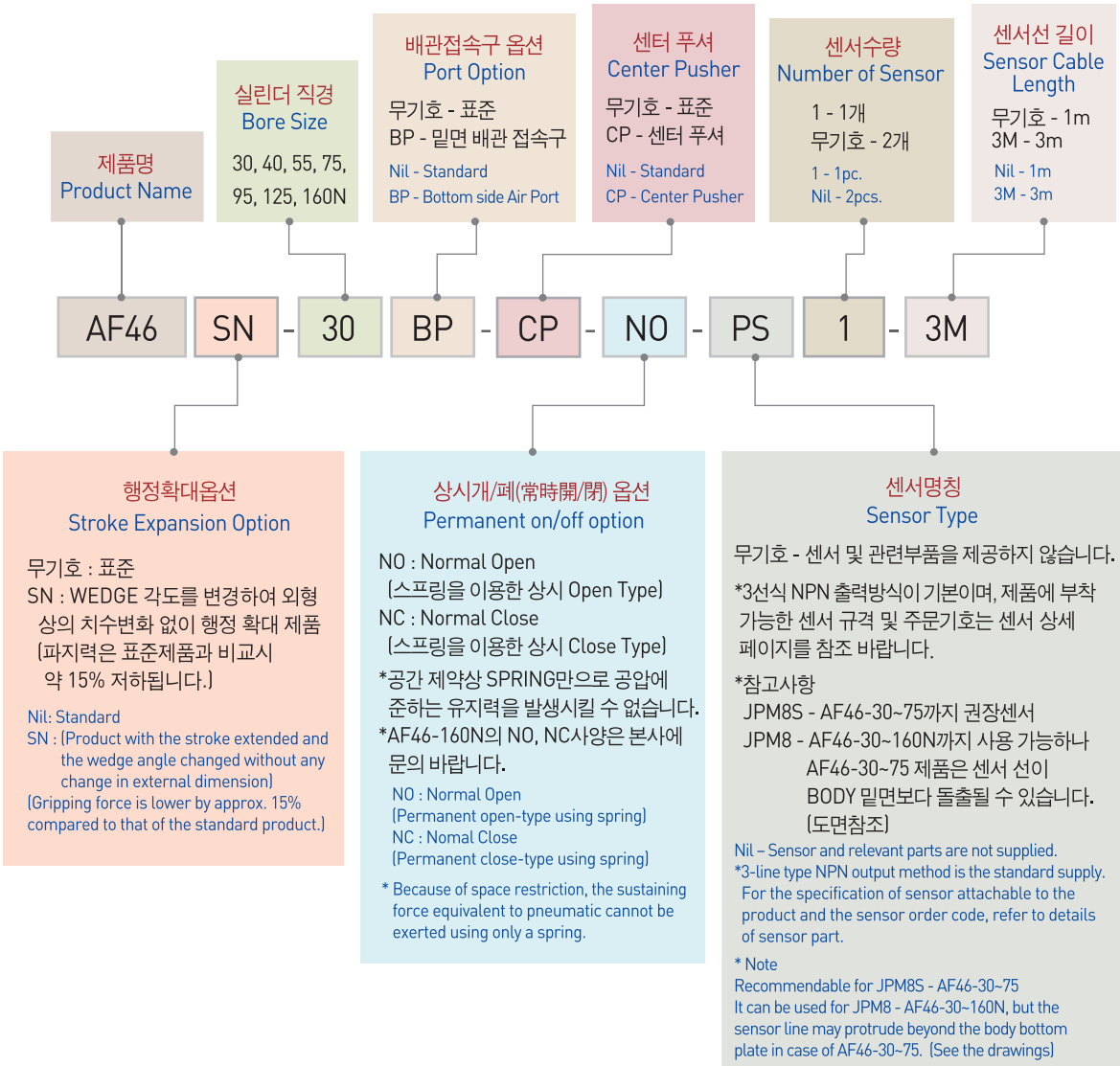

- AF101
- AF02
- AF03
- AF04P
- AF105P
- AF06
- AF10
- AF13
- AF13C
- AF14
- AF15
- AF316
- AF316L
- AF17
- AF117
- AF19
- AF24
- AF26
- AF28D
- AF30(SN)
- AF30L
- AF30SP
- AF46(SN)
- AF46N
- AF56N
- AF56L
- RAF56N
- MF16

☐ 제품사양 (Specification)

P=공기압력(bar) , L=작용점까지의 거리(mm)
P=Air Pressure(bar) , L=Exertion length(mm)

제품명칭 Products Name	AF46-30		AF46-40		AF46-55		AF46-75		단위 Unit
	Standard	AF46SN-30	Standard	AF46SN-40	Standard	AF46SN-55	Standard	AF46SN-75	
개폐범위 Stroke	8	10	12	15	16	20	20	24	mm
제품중량 Weight	0.24		0.43		0.75		1.30		kg
최대치구길이 Max. length attach	50		60		80		100		mm
배관접속구 Fitting size	M5		M5		M5		PF(G) 1/8		
파지력 : 열림시 Gripping force : Open	60.82P 1+0.01L	54.12P 1+0.01L	109.87P 1+0.008L	97.78P 1+0.008L	241.33P 1+0.01L	214.78P 1+0.01L	421.83P 1+0.007L	375.42P 1+0.007L	N
파지력 : 닫힘시 Gripping force : Close	52.97P 1+0.01L	47.14P 1+0.01L	98.1P 1+0.008L	87.31P 1+0.008L	233.48P 1+0.01L	207.79P 1+0.01L	403.19P 1+0.007L	358.83P 1+0.007L	N
1사이클당 공기소모량 Air consumption per cycle	6.8		19.9		46.0		103.6		cm ³
닫힘시/열림시 시간 Closing / Opening time	0.01/0.01		0.02/0.02		0.05/0.05		0.10/0.10		sec
반복정밀도 Repeat accuracy	0.01		0.01		0.01		0.01		mm
연속사용회수 Continuation usage amount	60		50		50		40		cpm
사용압력 Operating pressure	3~7								bar
주위온도 Ambient temperature	-5 to 60								℃
윤활 Lubrication	불필요 Needless								

제품명칭 Products Name	AF46-95		AF46-125		AF46-160N		단위 Unit		
	Standard	AF46SN-95	Standard	AF46SN-125	Standard	AF46SN-160N			
개폐범위 Stroke	26	31	32	39	50	58	mm		
제품중량 Weight	2.05		4.07		10.85		kg		
최대치구길이 Max. length attach	120		160		200		mm		
배관접속구 Fitting size	PF(G) 1/8		PF(G) 1/8		PF(G) 1/8				
파지력 : 열림시 Gripping force : Open	500.31P 1+0.008L	445.27P 1+0.008L	657.27P 1+0.01L	584.97P 1+0.01L	1216.44P 1+0.003L	1082.63P 1+0.003L	N		
파지력 : 닫힘시 Gripping force : Close	480.69P 1+0.008L	427.81P 1+0.008L	618.03P 1+0.01L	550.04P 1+0.01L	1137.96P 1+0.003L	1012.78P 1+0.003L	N		
1사이클당 공기소모량 Air consumption per cycle	213.8		466.6		1182.2		cm ³		
닫힘시/열림시 시간 Closing / Opening time	0.22/0.22		0.50/0.50		0.12/0.12		sec		
반복정밀도 Repeat accuracy	0.02		0.05		0.1		mm		
연속사용회수 Continuation usage amount	40		30		20		cpm		
사용압력 Operating pressure	3~7								bar
주위온도 Ambient temperature	-5 to 60								℃
윤활 Lubrication	불필요 Needless								

반복정밀도 : 연속 100회 작동후 측정치
After 100 consecutive strokes to end positions

작용점에서의 파지력 (Gripping Force From a Point of Action)

범례(Legend) : — 7[bar] — 5[bar] — 3[bar]

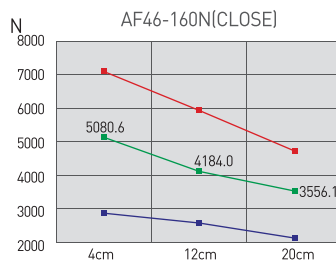
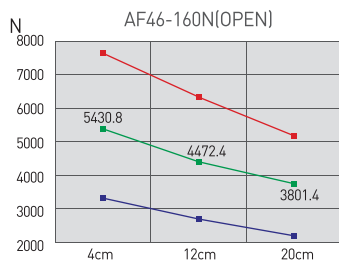
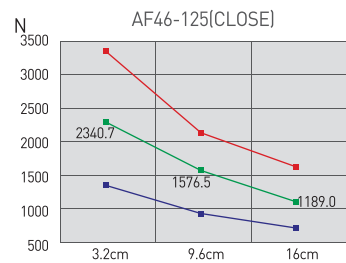
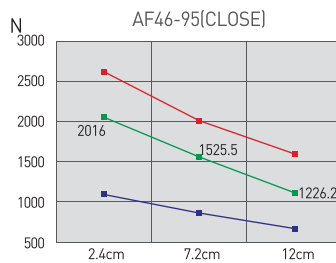
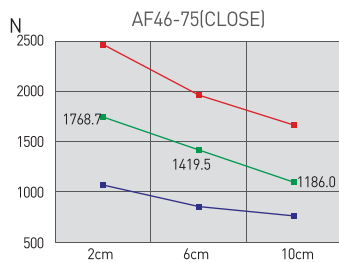
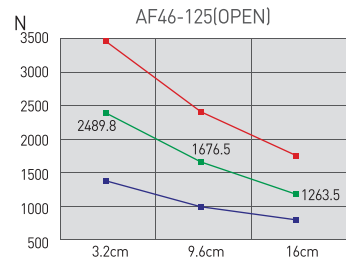
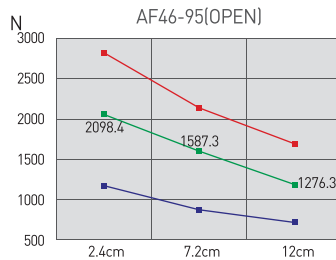
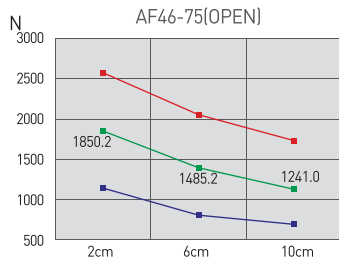
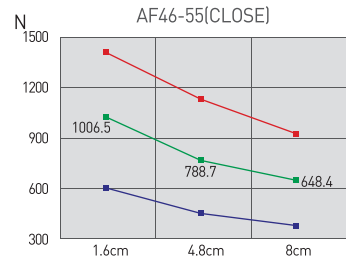
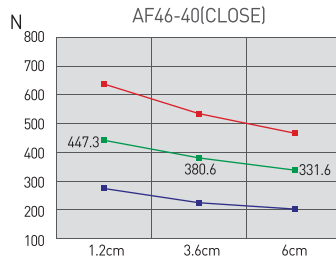
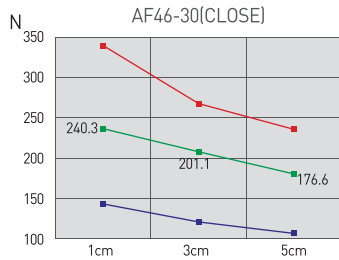
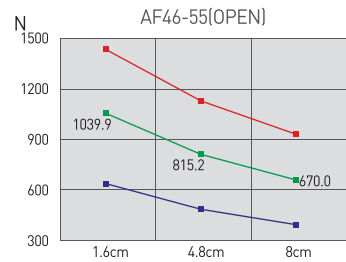
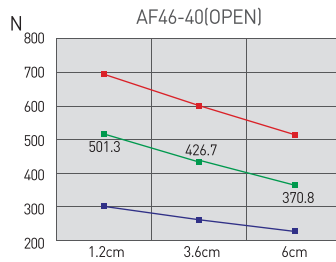
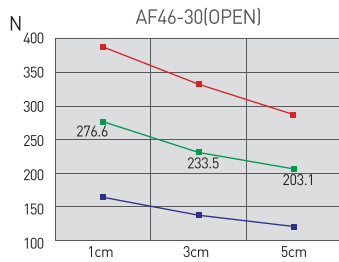

- AF101
- AF02
- AF03
- AF04P
- AF105P
- AF06
- AF10
- AF13
- AF13C
- AF14
- AF15
- AF316
- AF316L
- AF17
- AF117
- AF19
- AF24
- AF26
- AF28D
- AF30(SN)
- AF30L
- AF30SP
- AF46(SN)**
- AF46 N
- AF56N
- AF56L
- RAF56N
- MF16

AF46-30

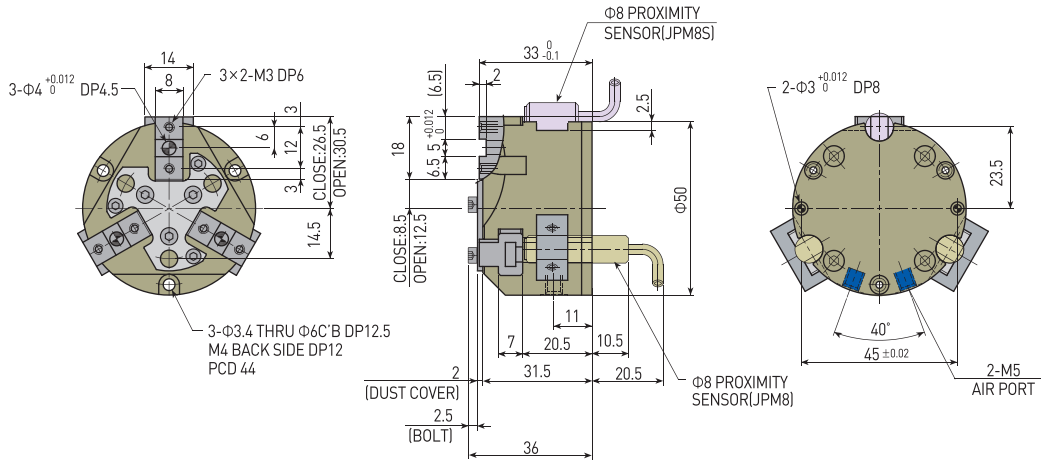

BP [Bottom Port] DIMENSION

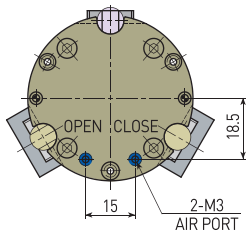

CP [Standard Center Push] DIMENSION

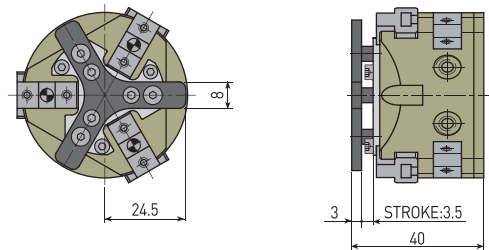

AF46SN-30 DIMENSION

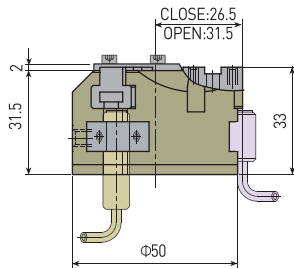

AF46□□-30...-NO(NC) DIMENSION

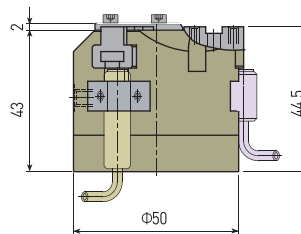

AF46-40

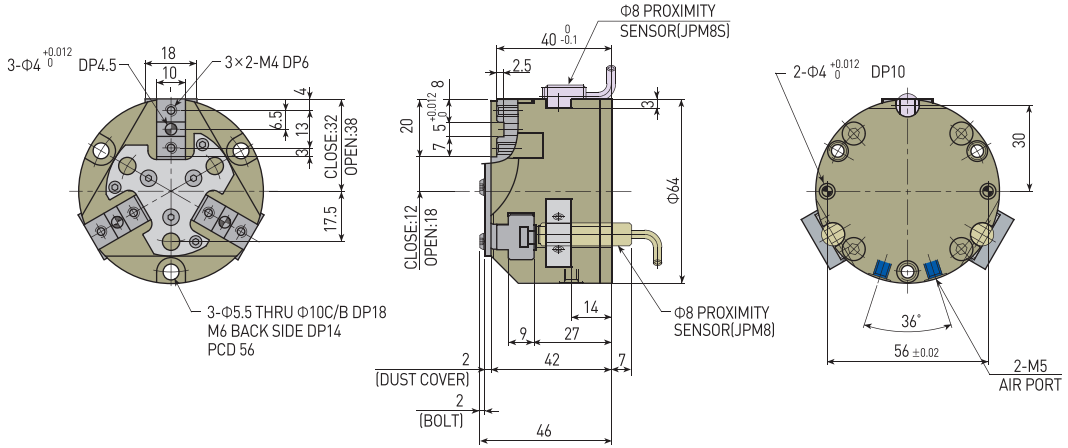

BP (Bottom Port) DIMENSION

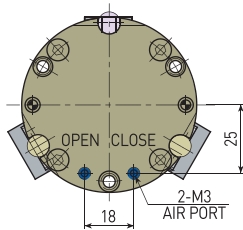

CP (Standard Center Push) DIMENSION

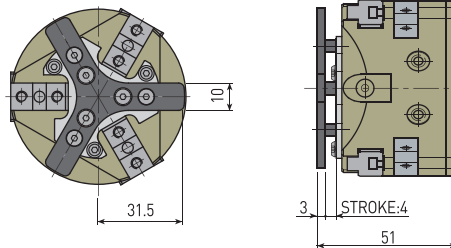

AF46SN-40 DIMENSION

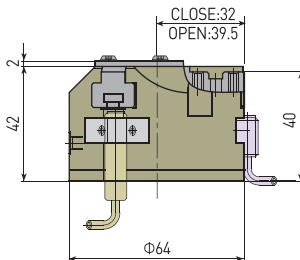

AF46□□-40...-NO(NC) DIMENSION

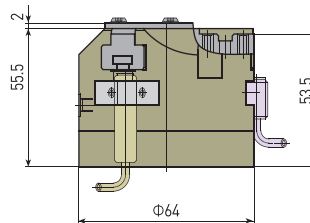

AF101
AF02
AF03
AF04P
AF105P
AF06
AF10
AF13
AF13C
AF14
AF15
AF316
AF316L
AF17
AF117
AF19
AF24
AF26
AF28D
AF30(SN)
AF30L
AF30SP
AF46(SN)
AF46 N
AF56N
AF56L
RAF56N
MF16

AF46-55

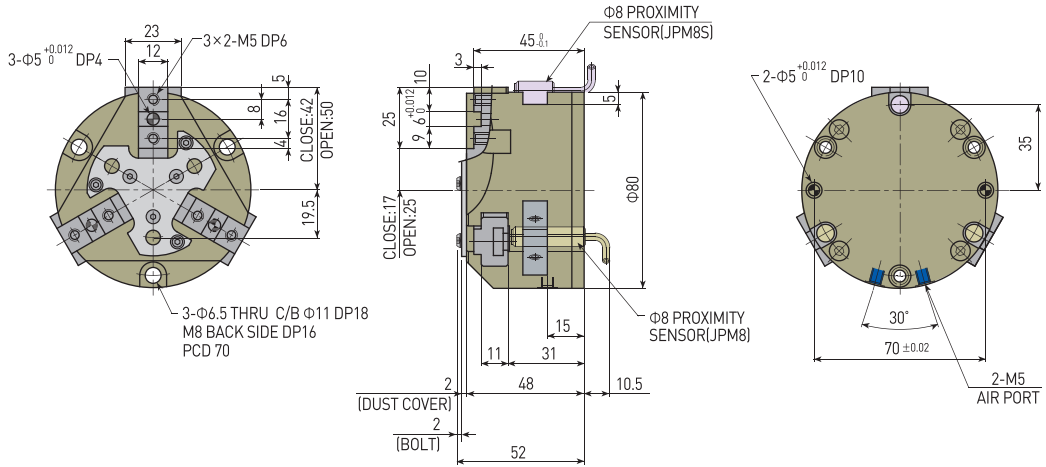

BP (Bottom Port) DIMENSION

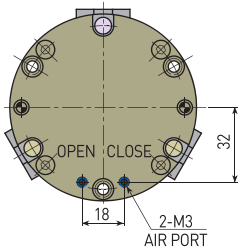

CP (Standard Center Push) DIMENSION

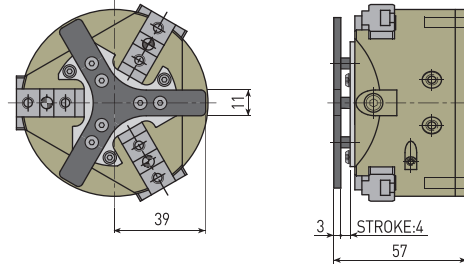

AF46SN-55 DIMENSION

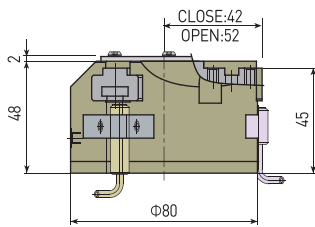

AF46□□-55...-NO(NC) DIMENSION

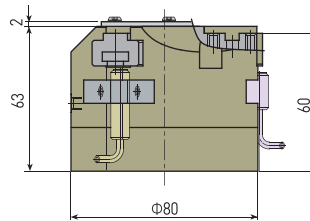

AF46-75

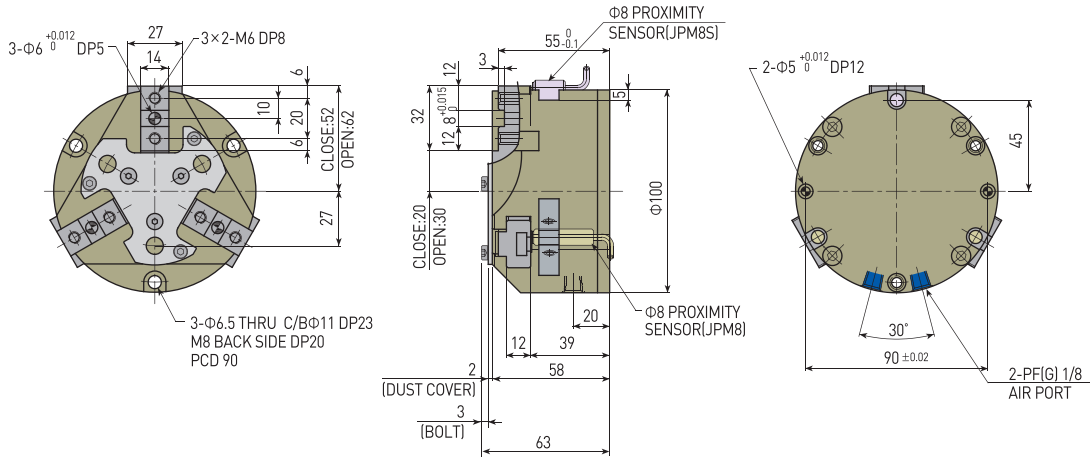

BP (Bottom Port) DIMENSION

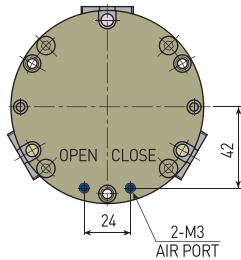

CP (Standard Center Push) DIMENSION

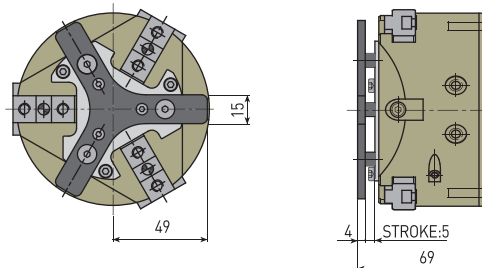

AF46SN-75 DIMENSION

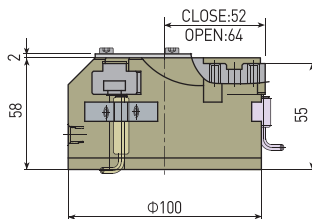

AF46□□-75...-NO(NC) DIMENSION

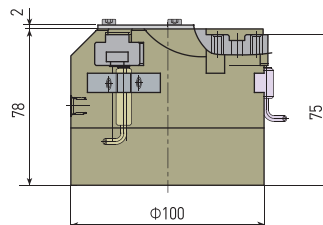

- AF101
- AF02
- AF03
- AF04P
- AF105P
- AF06
- AF10
- AF13
- AF13C
- AF14
- AF15
- AF316
- AF316L
- AF17
- AF117
- AF19
- AF24
- AF26
- AF28D
- AF30(SN)
- AF30L
- AF30SP
- AF46(SN)**
- AF46 N
- AF56N
- AF56L
- RAF56N
- MF16

AF46-95

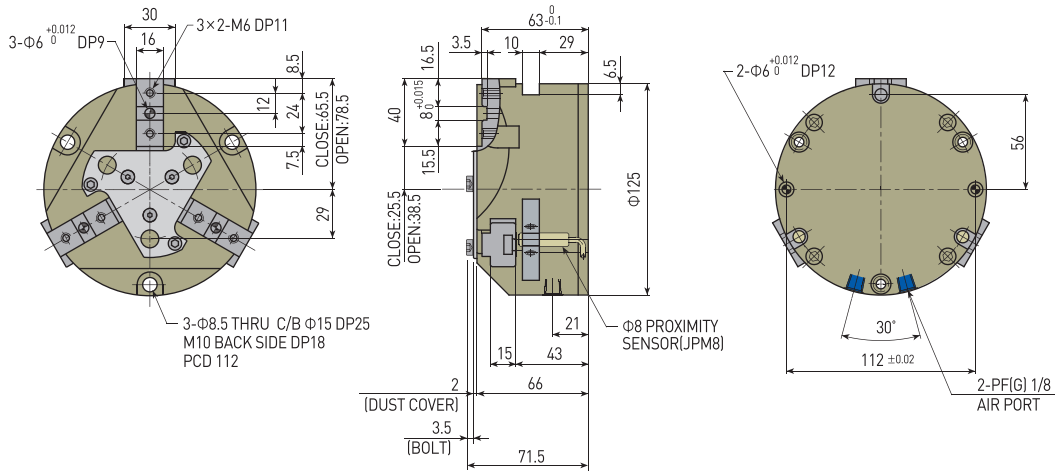

BP (Bottom Port) DIMENSION

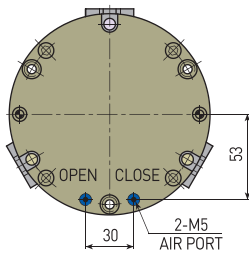

CP (Standard Center Push) DIMENSION

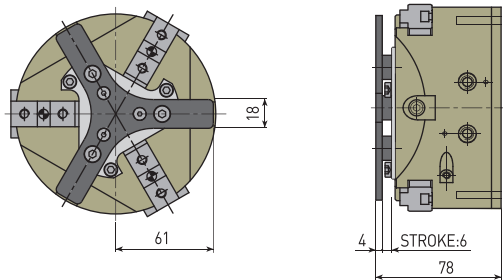

AF46SN-95 DIMENSION

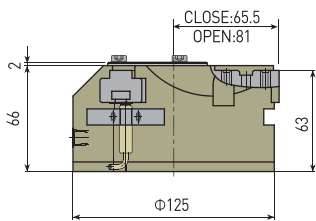

AF46□□-95...-NO(NC) DIMENSION

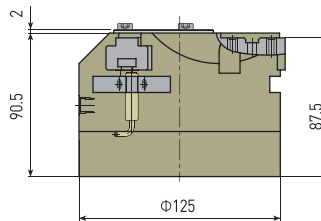

AF46-125

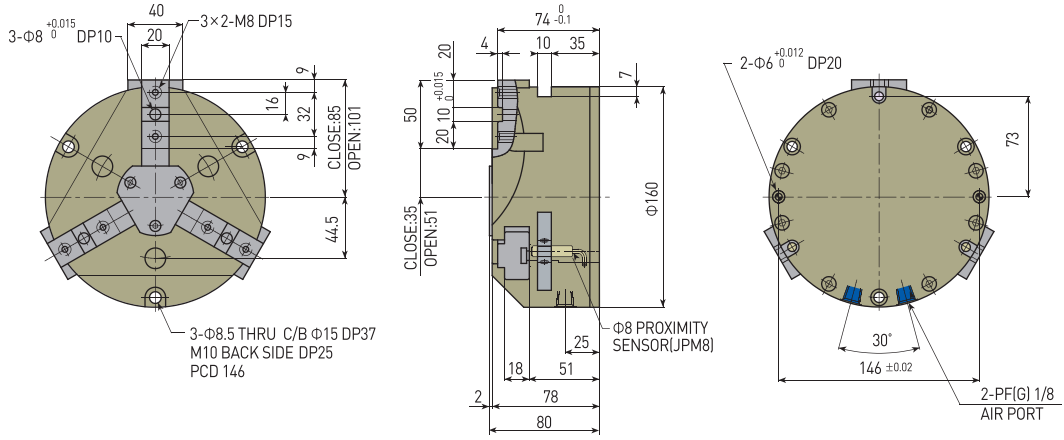

BP (Bottom Port) DIMENSION

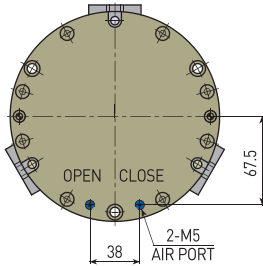

CP (Standard Center Push) DIMENSION

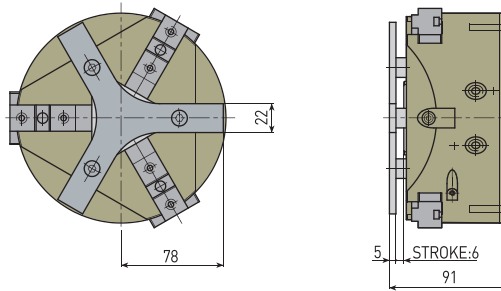

AF46SN-125 DIMENSION

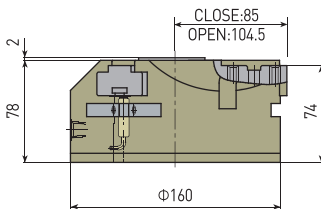

AF46□□-125...-NO(NC) DIMENSION

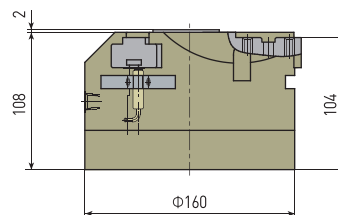

AF101
AF02
AF03
AF04P
AF105P
AF06
AF10
AF13
AF13C
AF14
AF15
AF316
AF316L
AF17
AF117
AF19
AF24
AF26
AF28D
AF30(SN)
AF30L
AF30SP
AF46(SN)
AF46 N
AF56N
AF56L
RAF56N
MF16

AF46-160N

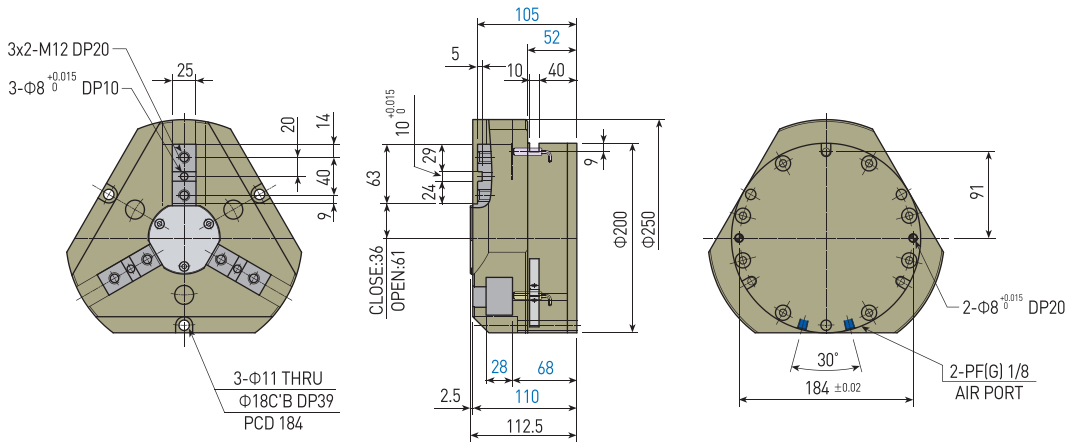

BP (Bottom Port) DIMENSION

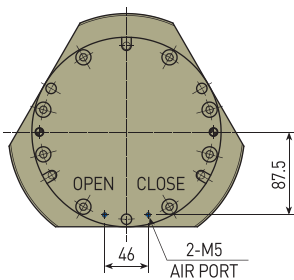

CP (Standard Center Push) DIMENSION

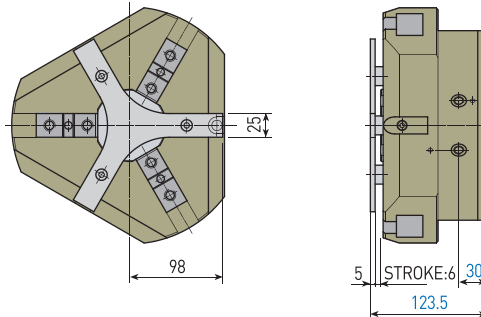

AF46SN-160N DIMENSION

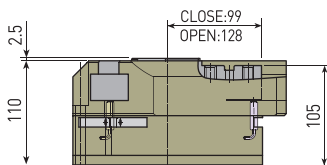

1. AF 46-160 구형제품의 작동상태를 개선하기위해 변경된 DIMENSION 입니다.
2. ■색의 수치는 변경된 사양이며 기타 치수는 구형제품 AF46-160과 동일합니다.

1. AF 46-160 legacy products in order to improve the operational status of the DIMENSION.
2. ■Number of color changes, and other specifications are the same dimensions as the old product AF 46-160.